

## Automatic Tape Dispenser Machine



Automatic tape Dispenser can be set according to the length of the cut, and cut off the tape straight, parallel to paste on the edge. Adhesive tape cutting length, paste the interval can be adjusted freely according to user needs.

### Parameters

Internal Diameter	25mm/32mm/75mm(1"/1.3"/3")
Outside Diameter	130mm(5.1")
Voltage	110V/60HZ (If want 220V,contact us)
Power	160W
cutting width	3mm to 25mm(0.1" to 1")
Cutting Length	13mm to 60mm(0.5 to 2.4)
Dimensions	170mm*300mm*165mm(6.7"*6.5"*11.8")
Weight	2.8kg(6.4lbs)

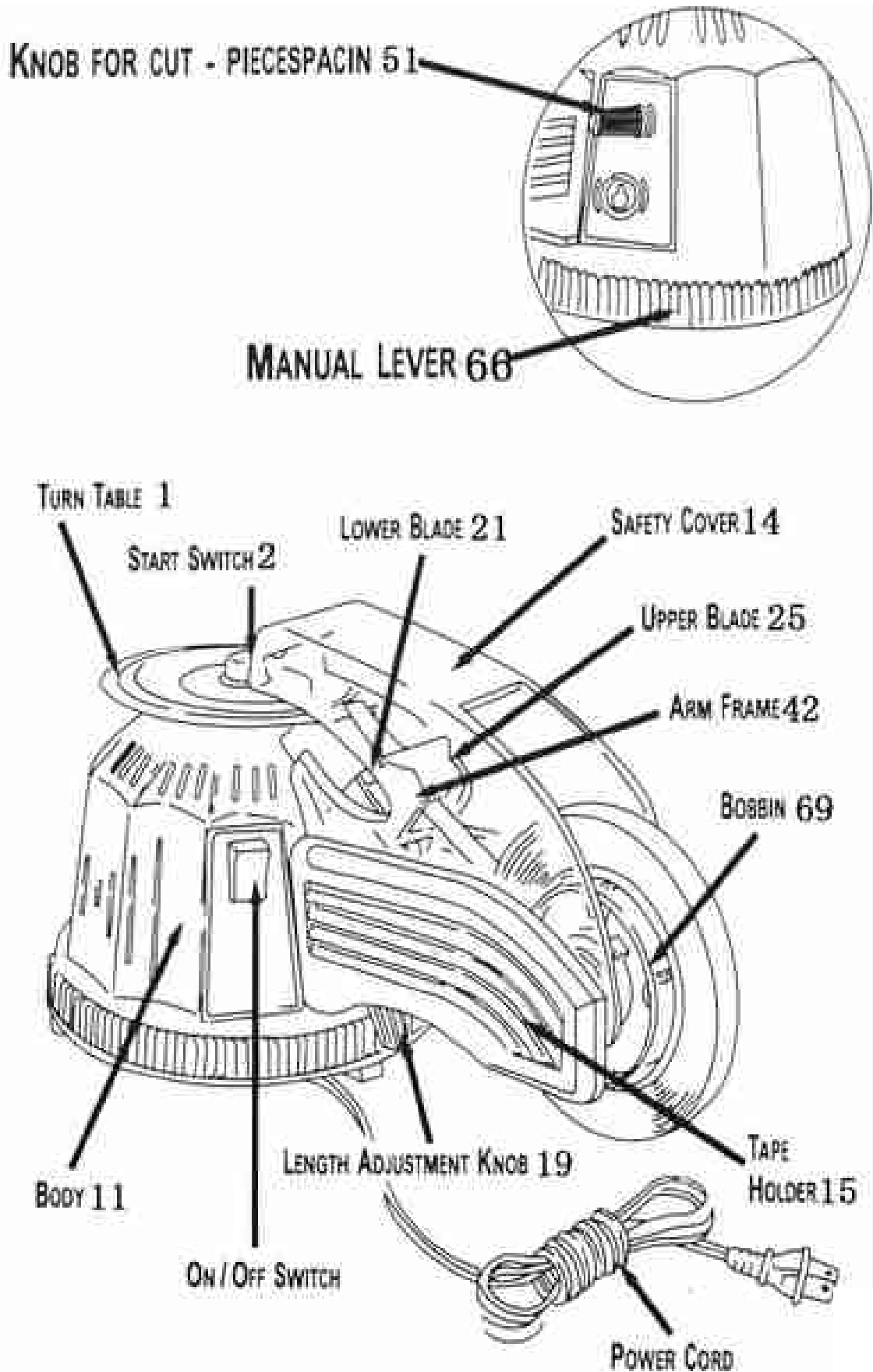

## Features

- Durable
- Lightweight
- Multi-users
- Cutting speed adjustment
- Cutting length adjustment
- Automatic cutting and arrange fitly

## How To Use

### Before Use

1. Make sure the ON/OFF switch is turned to the "off" position before you plug the Zcut2 in.
2. When you load the tape, make sure that the ON/OFF switch is "off".
3. The blades are very sharp. When the ZCUT2 is in operation, make sure the safety cover is down.
4. When there are finger marks, oil, and/or dirt on the carousel, the tape won't stick properly so use a dry cloth to clean the carousel.  
**Note: For major cleaning, wipe the carousel off with benzene or alcohol.**
5. To avoid finger shortening the life of the motor, run the ZCUT2 without tape as little as possible.
6. This is an industrial tape dispenser. It's not for home use. Do not use around children.
7. The ZCUT2 can be used efficiently by one or two people. Allow the motor to rest from time to time.

### How To Set The Bobbin

1. The ON/OFF switch must be "off". Note: When not in use, unplug the ZCUT2.
2. Choose the right bobbin  for the tape.

Note: Internal diameter 25,32,78mm. outside diameter Up to 130mm

3. Put the tape on the bobbin.

**Note: Check the direction of the bobbin, and push the tape to the limit of the flange.**

4. Pull out approximately 100 mm of tape. Put the bobbin on the tape holder.
- Note: If there is space between the tape core and bobbin, wrap a piece of

 around the bobbin to make it fit.

---

## How To Set The Tape

1. The ON/OFF switch must be "off". Open the safety cover **14**.  
Move the arm frame **42** using the manual lever **66**.
2. Set the blades as if they were going to "bite" the carousel
3. Bring the arm frame **42** away from the carousel.
4. Pull the tape through the blades and affix the tape to the carousel.  
**Note: When you stick the tape to carousel, be sure to pull the tape all the way through the middle of the carousel affix firmly.**
5. If you haven't set the tape correctly, try repeating steps 1 through 4.

## Operations

1. The ON/OFF switch must be "on".
2. Press the start switch **42** on the carousel. The cut pieces of tape will be distributed about half way around the carousel.
3. Before you begin operation, test the process by cutting two or three pieces, Check the precision length of the cut.
4. To make the tape feed all the way around the carousel, press the start switch **42** again.
5. If the motor over heats, the motor will automatically shut the ZCUT2 off. When that happens, let the motor cool before further use.
6. Whenever you open the safety cover **14**, the ZCUT2 will stop automatically.

**ASC365 International Ltd**  
**<http://asc365.com>**