

Attention: ①The laser tube can't be fixed too tightly to avoid damaging it; ②Be sure to keep the water inlet (laser tube high-voltage side) is located at the bottom of tube to keep the water filling the laser tube fully.

After Fixed the laser tube, the water inlet pipe which connect with water sensor should be connected with the high-voltage side water inlet mouth of the laser tube; the water outlet pipe should connect with the low-voltage water outlet mouth of laser tube (if the

weather is cold, in case of break the laser tube, we'd better scald the end of the water pipe with boiled water to make it soft.), As shown in Fig. F2-3, F2-4:

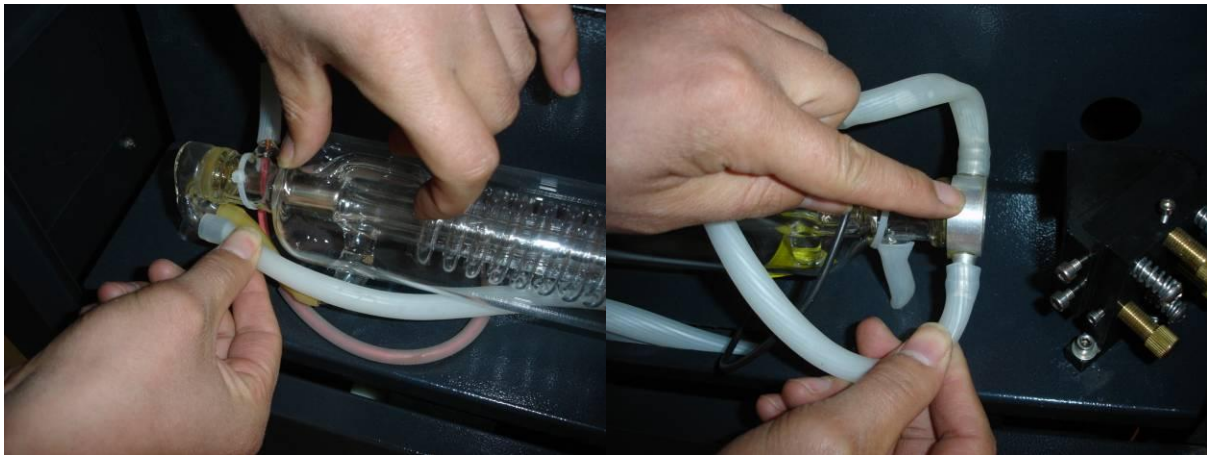

F2-3

F2-4

All the connectors must be butted firmly to prevent water leakage. The rubber pipe must be straight, can not be curled in order to avoid poor water flow.

Finally, let the high-voltage cable of the laser power supply connect to the high-voltage side post head of laser tube, the low-voltage cable of laser power supply connect to low-voltage side post head of the laser tube, as shown in Fig.F2-5 F2-6:



F2-5

F2-6

For security, please seal the post head of the high voltage side and low voltage with silicon gel.

2. Water Pump Installation

Please fill pure water into the water tank (the water level should be higher than the pump at least). Let the water pump outlet connect to water inlet of the machine, using another piece of water pipe connect to the water outlet of the machine, and put the other side of this water pipe into the water to complete the circulating water piping connection. As shown in Fig.F2-7, F2-8:



F2-7



F2-8

Connect the water pump power supply, at this time we can see that the laser tube is gradually filled with water. If the water can through the water outlet pipe smoothly, it shows that the pump is working properly.

In order to ensure the cooling water flow of the laser tube normally, a water protection sensor is installed in the water recycling system, when water pumps working poor or abnormal, the laser engraving machine will come into the protection state automatically. Then the laser tube will not emit the laser light. Therefore, in the course of routine maintenance, you should pay attention to the clean water pumps and water pipes.

3. Installation of Air Pump

Make the air outlet of the pump connected to the air inlet of the engraving machine with air pipe; ensure the outlet can vent air normally after turn on the power. As shown in Fig. F2-9, F2-10:



F2-9



F2-10

Air pump is very important in the system. High-pressure air runs through the air pump and blew out from the laser light-emitting window of the laser head. On the one hand, it can ensure the cleanliness of the focus lens, on the other hand, it can prevent the material inflame by the laser light. Therefore, in the routine maintenance, the user should pay attention to the air pipe, must ensure that it can not be twisty or damaged, otherwise abnormal air may lead to burning materials.

4. Installation of Exhaust Fan

First, let the suction inlet of the exhaust fan connect to the dust suction outlet of the engraving machine by a smoke pipe, and fix them with lock. And then take another smoke pipe connect the outlet of the fan, and put the other end of smoke pipe to outside. At last, connect the power supply wire well. As shown in Fig.F2-11, F2-12:



F2-11



F2-12

5. Safety Grounding

Morn laser engraver uses fourth type of laser tube. The type of drive is high-voltage-driven, so during users use the machine, they must comply with the "Safety Note ". On the other hand, it asks stringent requirement about the safety grounding to the users. The safe Line-to-Ground Resistance should be less than 5Ω . Specific connection method are shown in Fig.F2-12, F2-13



F2-12



F2-13

Attention please, bad grounding can cause high failure rate of equipment and at the same time may cause other safety incidents! ! !

The company won't assume any responsibility and obligation to the fault and the accident caused by bad grounding!!!

6. Optical Path Adjustment

After let all power cables connect well and electrify, turn on the engraving machine power supply, at this time, the machine starts to reset and return to the last origin point . All above shows that the machine is running normally, then turn on the laser power supply, begin to adjust the optical path. As shown in Fig.F1-14:

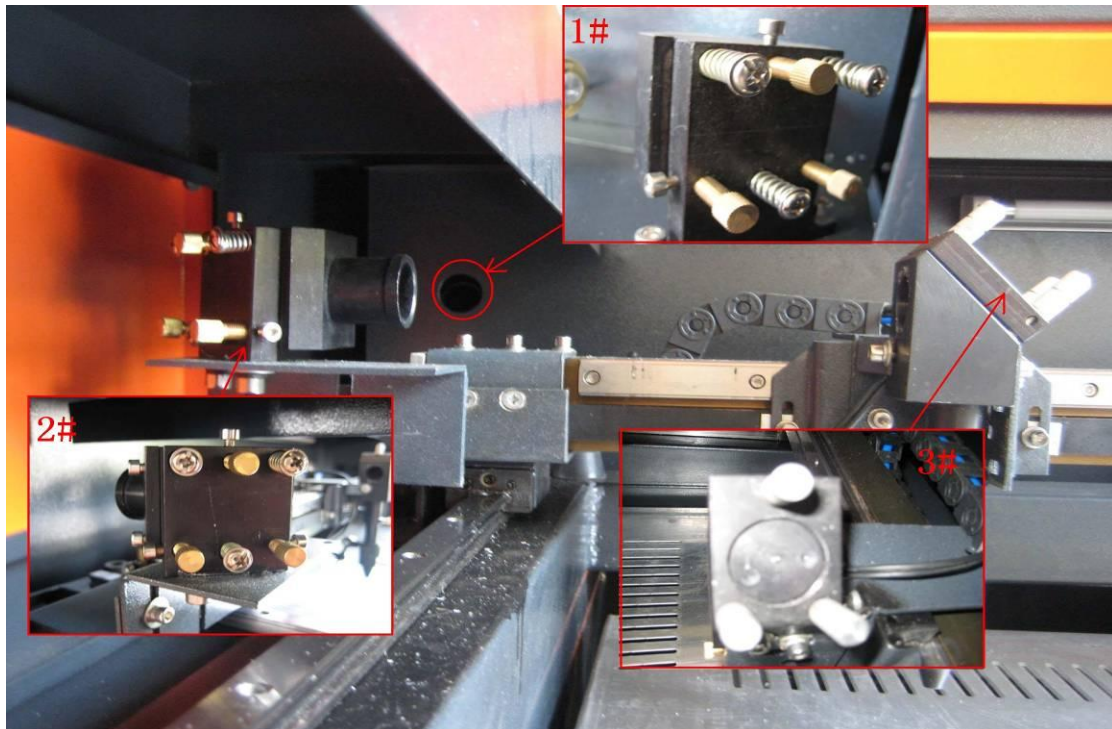

F2-14

Firstly, adjusting the laser position. Make the multilayer adjusting paper stuck on the 1# mirror frame, and then push the "Pulse" key on the control panel. There will be a burned point in the paper, check whether the light spot is in the center of the mirror, if the light spot is not in the center of the mirror center, we have to make the light spot in the center of the mirror by regulating the location of the laser tube.

Then adjust the 1# reflector mirrors. Move the beams to the nearest place to the 1# reflector; push "Pulse" to get a spot in the paper. And then move the beams to the farthest place from the 1# reflector, get another spot in the paper. We adjust the angle of the mirrors by adjusting the three screws on the back of mirror (clockwise rotation the above screw, the spot will be down; clockwise rotation of the lower left corner of the screw, the spot will move to right; clockwise rotation of the lower right corner of

screw, the spot will move to left.), to insure that all the spot are in the same place in the paper when and where the beam we move.

After adjust the 1# reflector mirror well, the next, adjust the mirror 2# as we do at the first step, move the laser head to the nearest side to 2# reflector , then make a spot in the paper , then move the laser head to the farthest place to 2# , make a spot.

We have to adjust the further spot overlap with the first spot by adjust the screws on the 2# reflector frame.

Note: As the best, the location of light spot should be in the center of mirrors. The light spot can not hit the edges of the mirrors. If playing in the edges, please continue to adjust the mirrors until the light spot in the central of them.

At last we have to check whether the light spots are superposition wherever the laser head is. If the spots can not coincide, please re-adjust the optical path by the way we talked above until the spots coincide

After finished the adjustment, we will check whether this laser spot is playing in central of the laser head light hole. If not, turn off the laser power supply, adjust the laser tube position. If it is left and right excursion, which side is biased on, we move the laser tube to this side direction. Such as: if left, we adjust the laser tube to left ; if right , we adjust the laser tube to right .

If the migration is up and down, we have to adjust the laser tube to the opposite direction, that is, if up, we will make the laser tube down; if down, we will make the laser tube up.

Note: The above adjustments is just for a low-voltage side of laser tube (light side), if we want to adjust high-voltage side of the laser to achieve the same effect, then the adjusting direction is opposite.

The detailed description of how to adjust optical path, please see Chapter 4 "Alignment Standards of Optical Path".

After adjustment of optical path, please close the laser tube protective cover.

I Chapter 3 the Operation of laser machine

Besides use the computer to control the function key, we can use the Control Panel. The following is the brief instruction of control panel and main function.

There are 16 function keys and one LCD Panel in the Control Panel:



I.3.1 Introduction of Main Interface

Idle Interface (display system time: day/month /year)

```

File: XX    File Number: XXXX
Max Power: XX.X%
Run Speed: XXX mm/s
System Idle: 25/12/2010
  
```

Figure: 3.1-1

Running Interface (display run time of the selected file: hour/minute/second)

```

File : XX    File Number : XXXX
Max Power : XX.X%
Run Speed : XXX mm/s
System Run: 00.12.40
  
```

Figure: 3.1-2

Main Interface (Pause)

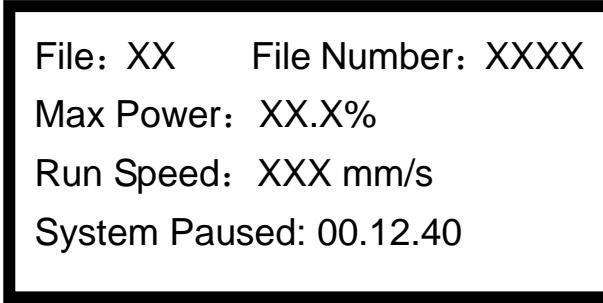

```

File: XX      File Number: XXXX
Max Power: XX.X%
Run Speed: XXX mm/s
System Paused: 00.12.40

```

Figure: 3.1-3

Run finished interface (display the total run time of the last file: h./min./sec.)
 In this interface, if “ESC” key is pushed down, the interface will return to idle interface, that is to say, the figure 3.1-1.

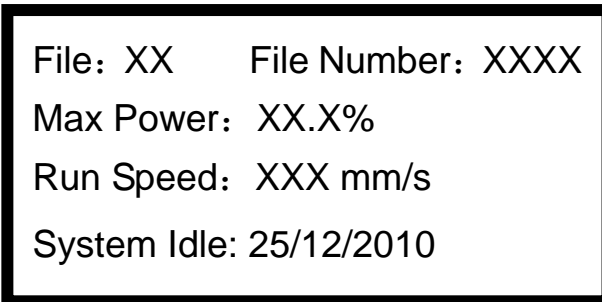

```

File: XX      File Number: XXXX
Max Power: XX.X%
Run Speed: XXX mm/s
System Idle: 25/12/2010

```

Figure: 3. 1-4

The interface in Figure 3.1-1 shows when the system is idle. “File” means the number of the memory file presently selected by the operator. If it is 00, it means the memory file is not selected. “File Number” means the processing times of the current file number. “Max. Energy” and “Speed” separately mean the maximum energy and the engraving speed set on the keyboard. Maximum energy is expressed by percentage and accurate to 0.1%. The unit of processing speed is millimeter a second (mm/s). When there is a laser tube, the interface only shows the maximum energy of this tube as shown in the above figure. If there are two laser tubes that are enabled, the interface show the maximum energy of two laser tubes. The main idle interface is taken for example as shown in Figure 3.1-5. On the interface shown in Figures 1-1 and 1-4, you can press any keys on the keyboard. On the interfaces shown in Figure 3.1-2 and 3.1-3, some keys can’t respond.

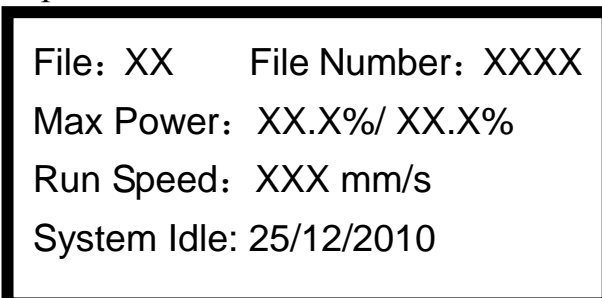

```

File: XX      File Number: XXXX
Max Power: XX.X%/ XX.X%
Run Speed: XXX mm/s
System Idle: 25/12/2010

```

Figure: 3.1-5

I.3.2 Introduction of key

(1) Reset

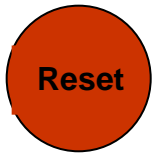

On any interfaces, press the Reset key (or when the system is powered) and the mainboard will be reset. The machine will seek for the origin (configured according to the user's parameters through start-up and reset) and show the "Reset-in-progress" prompted in the interface. The machine having successfully returned to the origin, the laser head will automatically move to the setpoint set last time. If the last processing is successfully completed prior to the resetting, the system will at this time return to the interface in Figure 3.1-1; if the last processing is not completed (i.e. the power supply is cut off during the processing), the system will at this time show as follows:

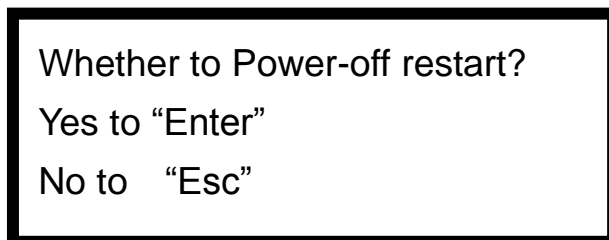



Figure:3.2-1

Pressing the "Esc" key in this interface and this de-energizing for continuous engraving will be cancelled and the system return to the interface in Figure 3.1-1. If processing was once started, the figure uncompleted in the former processing can't be de-energized for continuous engraving; if the "Enter" key is pressed in this interface, the de-energizing for continuous engraving can be started in order to process such a figure continuously.

 <p>Prompt</p>	<p>After the de-energizing for continuous engraving is started, the interface will show "Looking for cutoff point, please wait". The waiting time has something to do with the data size of last processing. The larger the data size is, the longer the search for the cutoff point by the mainboard is. Generally speaking, if the power is cut off after the figure processing of one hour, the time that the mainboard looks for the cutoff point is approximately one minute when the de-energizing for continuous engraving is started after it is powered next time.</p>
--	---

(2) Laser



On the system idle interface, the work finished interface, the system paused interface and the interface to prompt whether to de-energize for continuous engraving, press the “Laser” key and the laser outputs on the bursting. The time of open laser may be set. If the time is set to zero, then the outputting time is the time when the “Laser” key is pressed, that is to say, press this key for outputting and release it for blanking. If the time is not zero, such as, 100ms, then the laser flash 100ms when you push down the laser key. You can press the “Down” key on pressing the “Laser” key to start manual cutting. The laser energy of burst is the maximum energy value set on the keyboard. It is no use to press the “Laser” key on other interfaces. If the water protector is started and something wrong happens to the protector, no laser will be outputted after the laser and the interface prompts dislocation.

(3) Max. Power key



On four main interfaces (i.e. idle system, running system and suspended system, work finished interface) this key can be pressed. On pressing this key, if the manufacturer only provides a single laser tube or if there is a double-path laser tube, but the user only enables one path, it only shows the maximum energy of this-path laser tube and the interface shows the same as Figure 3.2-2. If two laser tubes are enabled together, it will show the maximum energy of two laser tubes and the interface shows the same as Figure 3.2-3.

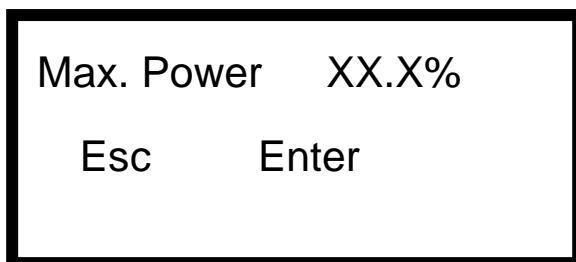

Figure: 3.2-2

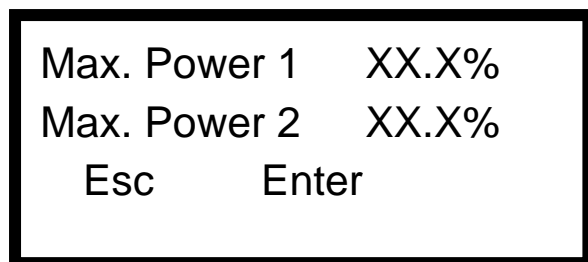

Figure:3.2-2

(4) Min. Power key



The display interface and the operating mode of this key are similar to those of the “Max Power” key.

(5) Speed key



On four main interfaces (i.e. idle system, running system and suspended system, work finished interface) this key can be pressed. Press this key and the interface will show the same as Figure: 3.2-4.

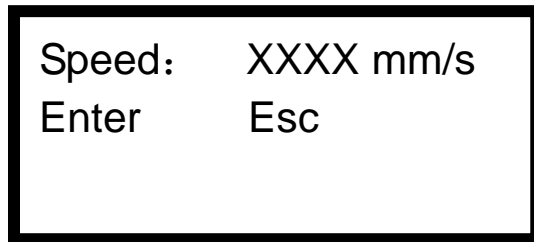
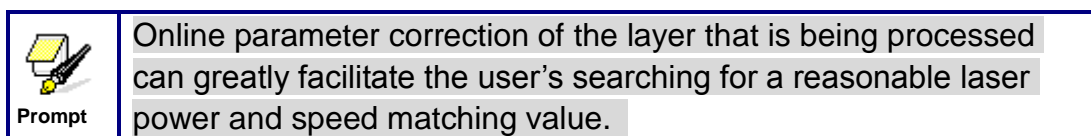

Figure: 3.2-4

The operating mode of this key is similar to that of the “Max Power” key.

When the PC software generates the cutting/engraving data file, if a certain or all the parameters of the maximum power, the minimum power and the speed parameter are set at 0, the value set on the keyboard will be taken as the corresponding parameter in the idle state. Once the work is started, what is shown in the display interface is the parameter of the layer that is being processed now.

The power and the speed parameters corrected when the work is not started will influence the following operations: bordering, bursting and manually shifting the axle on the keyboard. If the three parameters will be modified after the work is started, it will only influence the layer that is being processed, but neither the keyboard parameters set in the idle state nor other layer parameters.



(6) File key



Press the “File” key in the idle system interface or the work finished interface and two pages will appear. Press the “Up” and “Down” key and you can turn the pages up and down. The interface will show the following in turn:

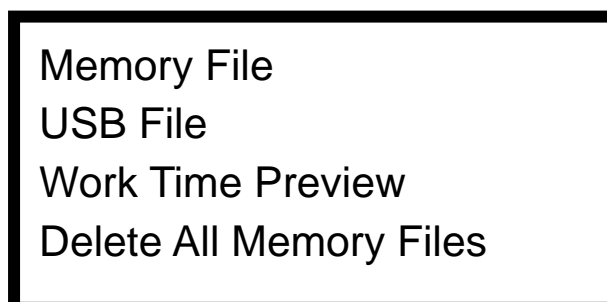

Figure:3.2-5

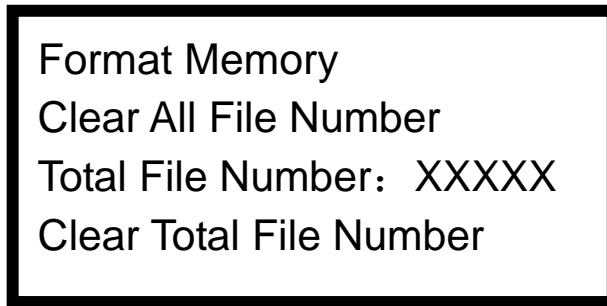

Figure: 3.2-6

Brief the following items separately:

- ◆“Memory File”: the related operations on the memory file such as processing, bordering, copying, deletion and etc.
- ◆“USB File”: the operations on USB file, such as copy to memory and deletion.
- ◆”Work Time Preview”: press this entry, the work time of the currently selected file will be calculated (you can also lower the memory file on the menu to start the work time preview feature of a certain file), calculated time according to the file size and complexity of the graphics, in general, if the actual work time is several hours, then the calculated time may require ten seconds or even more. The work time calculated is consistent with the actual working hours, accurate to the millisecond.
- ◆“Delete All Memory Files”: to delete the data of all memory files on the mainboard.
- ◆“Format Memory”: to format the memory on the mainboard. There are “Quick Format” and “Complete Format” for option. If there is some abnormality in memory, you may check the invalid block with the format function.
- ◆“Clear All File Number”: to delete the corresponding processing times to each memory file.
- ◆“Total File Number”: to show the present total times of processing by the machine.
- ◆“Clear Total File Number”: to clear and recalculate the total file number.

Move the cursor by way of the up and down directional keys to select an item first, and then press the “Enter” key to enter the submenu. On selecting “Memory File” or “USB File”, if the callee has no files, the interface will show the information of no file, otherwise it will show the numbers and names of all object files (the suffix name of object file is .rd). The processing times corresponding to this file is shown after the file name in the “Memory File” interface. Each page has four files:

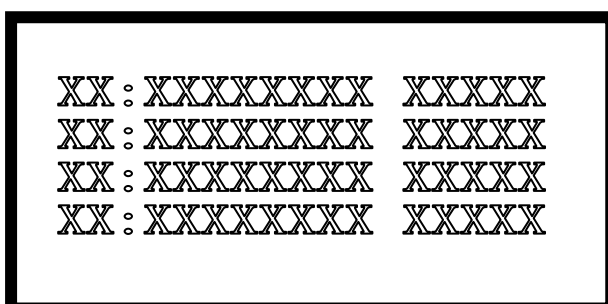



Figure: 3.2-7

Select a certain file by pressing the directional keys (move the cursor with the up and down keys and turn pages with the left and right keys) first, and then press the “Enter” key to enter the submenu. For memory file, it supports such six items as “Copy to USB”, “Run”, “Deletion”, “Work Time Preview”, “Track Frame” and “Clear File Number”.

On pressing the “Enter” key when you select the “Run” item, directly start the processing of this file and the interface shows the same as Figure 8.1-3 (Running Interface); selecting “To USB” and pressing the “Enter” key, this memory file will be copied to USB disk. If copying fails, the interface will show the error information; if copying succeeds, the system will return to the prior interface after the bell rings. On selecting the “Deletion” and pressing the “Enter” key, this file in the memory will be deleted. Selecting the “Work Time Preview” and pressing the “Enter” key, to start the work time preview feature of the certain file. If “Track Frame” is selected, the frame of the graph is previewed. Then if “Clear File Number” is selected, the work number of the certain file is set to zero.

For USB files, it supports such two options as “Copy to Memory” and “Deletion”, the operation of which is similar to that of memory file. In the operation of file copying, if the interface shows the error information, please press the “Enter” key or “Esc” key and the interface will return to the prior one.

 <p>Prompt</p>	<p>This system supports such file formats of USB as FAT32 and FAT16, but it can identify them when the files are put under the root directory of USB. The file name of more than 8 characters will automatically be cut out by the system. The file name that has only English letters and digits will not show when they are copied to the mainboard. The files copied from the mainboard to USB will be placed under the root directory of USB.</p>
--	---

(7) Start/Pause key



Under the four main interfaces it is ok to press the Start/Pause key. Press this key on the system idle interface or work finished interface; the selected file will be processed. Press this key under the running system interface, and the work will be suspended. Press this key under the suspended system interface, and the suspended work will continue.

(8) Origin key



It will respond when this key is pressed under the idle system interface or the work finished interface. If the single setpoint logic is selected by the system, press this key and the mainboard will take the current X/Y-axle position of the machine as the relative origin of the figure; if the multiple setpoint logic is selected by the system, it is invalid to press this key at any time.

(9) Frame key



It is valid to press this key under the idle system interface and the work finished interface. Press this key and the bordering will be operated on the currently selected file.

(10) Esc and Enter key



Press the Esc or Enter key under different interfaces means to confirm or deny this operation.

(11) Directional Keys (Up, Down, Left and Right keys)



In addition to being used for modifying parameters and moving the cursor as abovementioned, the directional keys can be used to move the kinematic axis under such three interfaces as idle, suspended system or work finished interface. Under such three interfaces, press the Left and Right keys to move X axis and press the Up and down keys to move Y axis. If the inching distance is set at 0, the moving time means the time of pressing this key, which means that movement starts after the one of the keys is pressed and movement stops after the keys are released. Where the inching distance is not 0, the corresponding axis will move for the corresponding inching distance after one of the directional keys is pressed once. In the movement processing the speed can be increased or reduced automatically in order to reach the maximum/minimum coordinates. The maximum speed of key movement is the speed value set on the keyboard when the system lies idle.

 Prompt	After the polarity of directional signal for each axle of the machine is adjusted well, if you press the Left key and the X axle will move rightward; and if you press the Up key and the Y axle will move down, which mean the key polarity of the axles moving to the opposite direction is not right. In such a case you should modify the key polarity of this axle.
---	--



(12) Z/U key (Function key) in the middle of directional keys

The Fn key can be pressed when the system is idle or the work is finished. On pressing this key, it will show three pages and nine entries in the following interface:

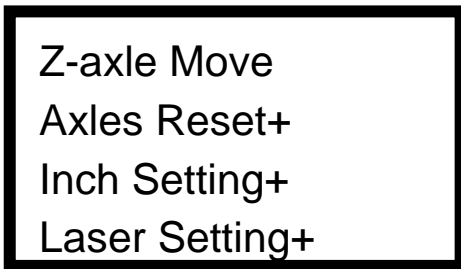

Figure: 3.2-8

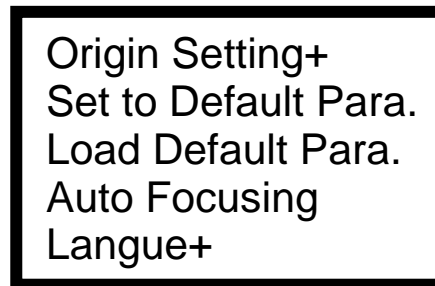

Figure: 3.2-8

1) Press the Up and Down keys to select the cursor position. When the cursor stops at “Z-axle Move”, press the Left and Right keys and the system will move the Z axle. If the inching distance is 0, Z axle will continuously move; if it is not 0, Z axle will move the well-set inching distance value.

2) When the cursor stops at “Axles Reset”, press the Enter key and it will show four entries as follows:

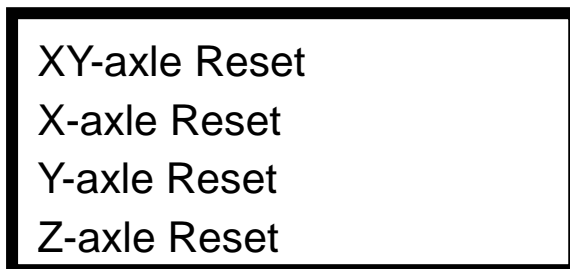

Figure:3.2-10

Press the Up and Down keys to select the desired entry. Press the Enter key and the corresponding axles will reset (Only when the reset of this axle is activated in the manufacturer's parameters can the resetting will function). Press the Esc key to return to the prior menu.

3) When the cursor stops at “Inch Setting” or “Laser setting”, the inching distance or the Laser shot time can be set.

4) When “Origin setting” is selected, it will show below:

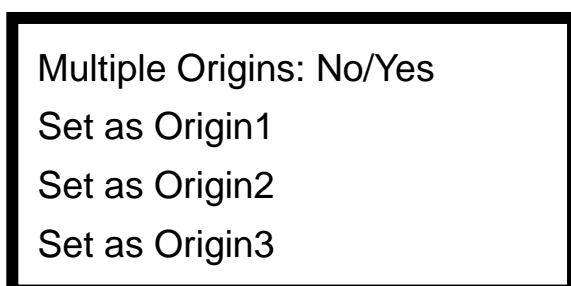

Figure: 3.2-11

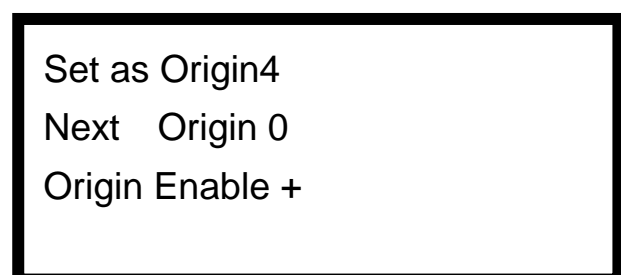
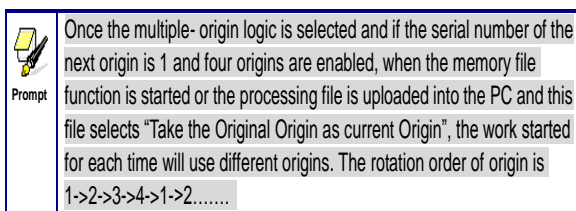

Figure: 3.2-12

- Multiple Origins: “Yes” or “No” can be selected. If you select “No”, the system will use the single-origin logic. You can press the “Origin” key and set the origin, and only this origin can become valid. If you select “Yes”, the system will use the multiple- origin logic and the “Origin” key on the keyboard become invalid. In such a case, the parameter of each origin must be set in the menu as follows.
- Set as Origin 1/2/3/4: after the multiple- origin logic is enabled, you can stop the cursor at “Set as Origin 1/2/3/4”. Press the “Enter” key on the keyboard and the system will take the coordinate figures of current X/Y axes as the corresponding ones to the origin 1/2/3/4.
- Next Origin: there are such five digits as 0~4 for option, which are the origins to be used for the next figure. Origin 0 means the origin set by the “Origin” key on the panel in the single- origin logic. 1~4 means the serial number of the origins in the multiple- origin logic. Next origin can be modified to any one of origin 1~4, so as to control the start location of next work (the premise is that the origin is enabled), but it can't be modified to origin 0.
- Origin Enable+: after the multiple-origin logic is enabled, the four origins can independently be prohibited and enabled.



5) After the “Set to Default Para” in Figure 3.2-9 is selected and the Enter key pressed, the interface will show the specific password to be entered when set as default parameter. After the manufacturer regulates all parameters of the machine well (including all manufacturer parameters and user parameters), this function can be used to store the well-regulated parameters to help users to recover the original parameters (including all manufacturer parameters and user parameters) through selecting “Load Default Para” when they regulate parameters improperly.

6) After the “Load Default Para” in Figure 3.2-9 is selected and the Enter key pressed, the “Successful Recovery” dialog box will pop up to prompt that all manufacturer parameters and user parameters are recovered successfully. You can return to the previous menu by press the Enter key.

7) When the cursor stops at “Auto Focusing”, press the Enter key to search for the focus(When there is z axes, and the z axes reset function is enabled, the auto focusing is valid); press the Esc key to return the prior menu.

8) The item “Langue” helps you to select a appropriate langue which is displayed on the panel.

I Chapter 4 Alignment Standards of Optical Path

During common use, there may appear some deviation with the optical path, resulting in no laser or light path is abnormal, then please refer to the following method to adjust the optical path:

Step one: First to ensure laser beam from laser tube to the center of 1# reflector mirror.

Step two: Affix multi-storey double sticky tape paper on the 2# reflector (Or other objects can be marked on), move laser beam to closest location of laser tube, press pulse (choose suitable power), get a spot on the paper (with special attention: In order to prevent the laser radiation wounding, with a piece of cardboard first to test the approximate location of the spot, and then adjust).

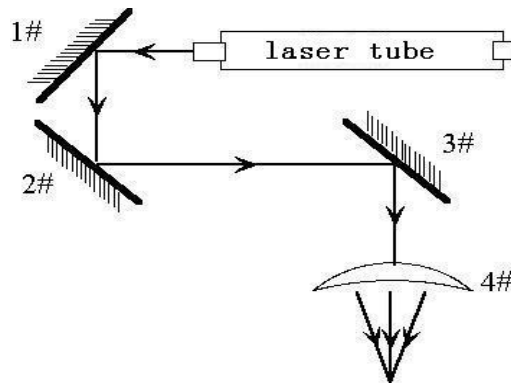

Step three: Move away the beam to the position far from the laser tube, press pulse, get another spot on the paper.

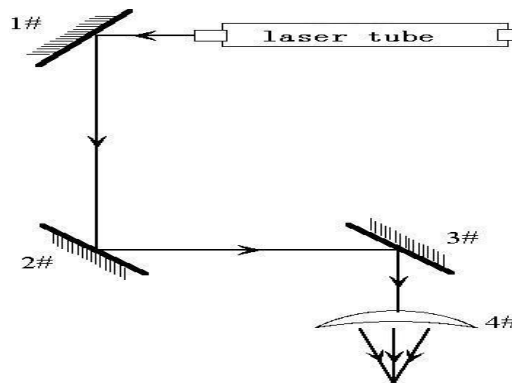

Step four: If the two spots are not superposition, adjust the screws on the back of the 1#mirror to make the laser fire on the same position as the first spot.

Step five: Repeat the second to the fourth steps until the two spots overlap completely. Moreover, the spots should be in the center of the hole.

Step six: Affix multi-storey double sticky tape paper on the 3# reflector ,move laser head to the nearest position from 2# mirror, press pulse(choose suitable power),get a spot on the paper.

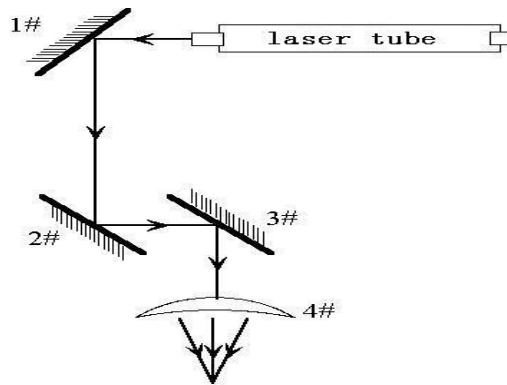

Step seven: Move away the laser head to the position farthest from the 2# mirror, press pulse (first to detect the approximate location of laser with a piece of cardboard to prevent wounding), get another spot.

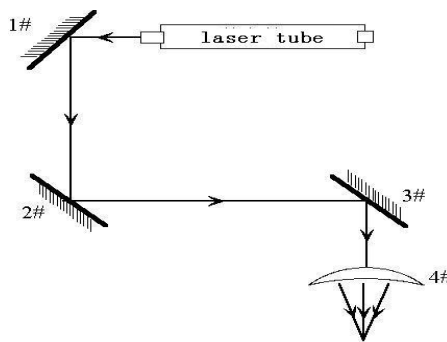

Step eight: If the two spots are not superposition, adjust the screws on the back of the 2# mirror to make the laser fire on the same position as the first spot.

Step nine: Repeat the sixth to eighth steps until the two spots overlap completely. Moreover, the spots should be in the center of the hole.

Step ten: Affix multi-storey double sticky tape paper on the 3# reflector, press pulse, get a spot on the paper. If it is in the center of light hole, then pass.

Step XI: If the laser light is not in the center of light hole, as below figure:

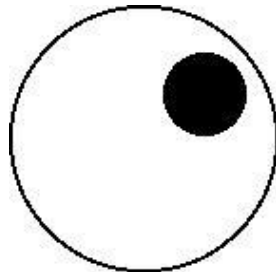

In the left Figure, the spot is upper and right biased.

Top to bottom bias: can only raise or lower the laser tube.

Inside and outside bias: only move the laser tube in or out to adjust.

In this case, it is essential to lower the laser tube (here refers to low-voltage side of the laser tube), and then, from the beginning of all the re-adjustment of the first step.

Note: The operator can't do the above working until after the professional training. Otherwise, the operator do this working must with the help of the professional .The operator must pay attention to security when adjusting, to prevent the laser radiation wounding.

I Chapter 5 Daily Maintenance and Common Faults

The stable working of the machine is inseparable with normal daily operation and maintenance. Here are some common daily maintenance and common faults analysis:

I.5.1 Daily maintenance

1. Replacement of the cooling water (clean water tank and replace recycled water once a week are recommended):

Quality and temperature of the cooling water can affect the lifetime of laser tube directly, suggest use purified water or distilled water, and water temperature should be below than 35 °C. When higher than 35 °C, please replace cooling water, or add ice cubes to lower the water temperature, (cooling device is recommended, or use two water tanks).

Note: To ensure that the laser tube full filled with cooling water before machine working.

2. Cleaning of Water Tank

First of all, turn off power, disconnect the water inlet pipe, let the inside water of the laser tube flow into the water tank automatically, open water tank, take out the water pump, clean water pump and water tank, put the pump back to water tank, insert the water pipe which connect water pump to water inlet mouth of the machine, finish all joints, then replace cooling water. Turn on the water pump power supply isolately, let the pump run 2-3 minutes (make laser tube full filled with water).

3. Cleaning of Exhaust Fan

After long time using, inside of fan will accumulate much solid dust, so the exhaust fan will make a great noise, and it is not conducive to the exhaust .When the exhaust effect become poor, we have to clean the fan and smoke pipe .Firstly, turn off the power supply, remove the two pipes from the fan, clean dust inside of the pipes, and then clean the dust inside of the fan.

4. Cleaning of Lens (daily cleaning is recommended before work, equipment must be in shutdown state)

As we have talked before, engraving machine has three reflector mirrors and one focus lens (1# reflector mirror is near the light outlet mouth of laser tube, the upper

left corner of the machine, 2# reflector mirror is at left side of the beam, 3# reflector mirror is on the top of laser head, the focus lens is located in the bottom part of the laser head), the laser is send out by the mirror reflecting and focus lens focalizing. Mirror is easy to be dirty, resulting in laser loss and mirror damage, you needn't remove 1#,2# and 3# mirror when cleaning them, Just using a cotton bar to dip some cleaning solution (acetone or alcohol) , swab carefully by rotating from central to edge of the lens.

Take out the focus lens from the laser head, using the same method clean it, after cleaning, put it back.

Note: ① you should wipe the lens carefully, cannot damage the surface coating; ② you should do that lightly, to prevent falling; ③keep concave side downward when install the focus lens.

5. Cleaning of Guideway (suggest cleaning every two weeks, equipment must be in shutdown state)

First of all, move the laser head to the far right (or left),wipe with a dry cloth until shiny clean, together with a little oil (sewing machine oil is recommended),push the laser head several times slowly along the guide, so that lubricant can be evenly distributed. Clean and lubricate the Y axis two guideways is the same as X axis.

Note: Please prepare for cleaning Guide - dry cotton cloth, lubricating oil.

6. Optical path inspection

Optical path system of the laser engraving machine is completed by the mirror reflection and focus lens focusing, and there is optical path bias with the focus lens, but the three mirrors is fixed by the mechanical part, optical path bias is very possible for them, although there is no optical bias normally, we still suggest you check optical path before working.

Please get detailed explanation from Chapter 4 "Alignment Standards of Optical Path "

I.5.2 Common Faults Analysis

No.	Phenomena of Malfunction	Analysis method	Solution
1	Open the machine but no movement	Check power supply of machine connects well or not	Make all power supply electrify again
		Mainboard parameter is right or not	Correct the parameters according to software operating manual
2	Working with nonstop laser	Mainboard parameter is right or not	Correct the laser parameters according to software operating manual
3	Desultory light when working	Check water circulation is swimmingly or not	Clean water tank, water pump and water pipe
		Voltage is stable or not	Add regulator for the laser machine
4	Self-test abnormal when starting	Mainboard parameter is right or not	Correct the X and Y axis direction ,limit position parameters according to software operating manual
5	After output data ,machine no action	Check whether the data port choice is correct.	Choose correct port
		Check whether turn on the machine	Turn on the machine
		Check whether connected ground wire for the machine	Connect ground wire
		check whether installed the USB driver	install the USB driver
6	No laser when working	Check whether optical path is bias	Adjust the optical path
		Check whether the cooling water is running	Ensure the water is running
7	Can't detect the laser equipment	The computer or USB communication problem	Change computer or USB line

II RDCAM V6.0 User Manual

II Chapter 1 Overview

II.1.1 Laser engraving cutting system introduction

Laser engraving cutting system through a computer numerical control machine tools to achieve effective control, according to the user's different requirements of the completion of processing tasks. This manual describes how to use the software to complete the task of laser processing



II.1.2 Environmental requirements

- (1) Windows XP operating system and above, XP recommended。
- (2) Above CPU586,above PIII or PV recommended。
- (3) Memory, above 1G recommended

II.1.3 Software running

Embedded software can be embedded in CorelDraw、AutoCad、CaDian2010 and Illustrator CS5 software, the software is similar to the operation, embedded software, installation methods, please refer to <<RDCAM software Setup Manual >>



1.3.1 Run CorelDraw

- 1>Run CorelDraw。
- 2>Import graph to CorelDraw, or draw some graphics。
- 3>Click toolbar  button , then RDCAM running。



1.3.2 Run AutoCad

- 1> Run AutoCad
- 2> Import grahic to AutoCad, or draw some。 3>Click toolbar  button then RDCAM running.

1.3.3 Run Cadian2010

- 1>Run Cadian2010
- 2>Import grahic to Cadian, or draw some.
- 3>Click toolbar  button then RDCAM  running

1.3.4 Run Illustrator CS5

- 1>Run Illustrator CS5。
- 2> Import grahic to Illustrator, or draw some.
- 3> Click toolbar  button , then RDCAM running。

II Chapter 2 Software installation

II.2.1 Install steps

- (1) Double-click the RDCAMSetup.exe under the installation directory, the following dialog box appears:

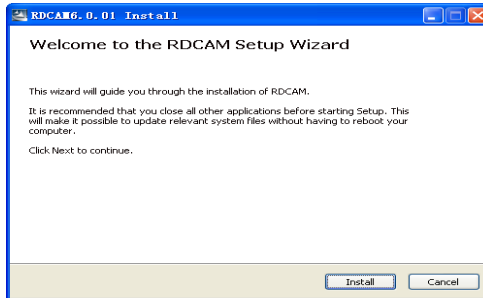

- (2) Click **【Install】**, when extract copy is to be completed, the installation main interface appears:

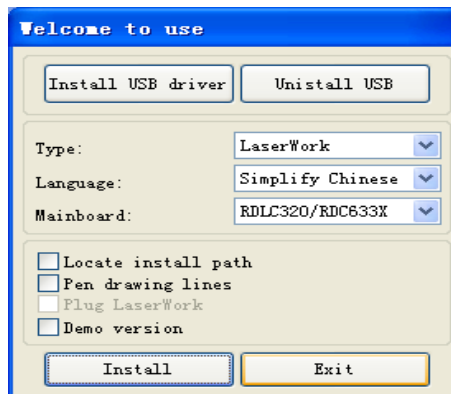

II.2.2 Installation settings

The installer can choose different installation content.

- 1> Install/Uninstall USB driver , reference 《Install USB driver》
- 2> According to the different customer application needs and the habit of using to select the type of software
 - a. Stand-alone software LaserWork.
 - b. The software that plug-ins to CorelDraw. Support the version from Coreldraw11 to X5.
 - c. The software that plug-ins to AutoCad. Support the version from 2004 to 2010.
 - d. The software that plug-ins to Cadian.
 - e. The software that plug-ins to Illustrator.
- 3> Choose a different installation languages

At present, it support Simplified Chinese, Traditional Chinese, English and the custom language type.
- 4> Select the software matches the motherboard

The software can support three kind of motherboards:RDLC430、RDLC320、RDC633X. Both RDLC320 and RDC633X are compatible, but RDLC430 is different. So, please choose the corresponding software with motherboard. Otherwise, it does not work.
- 5> Locate install path

When install the LaserWork, default install path is “C:\”, for change the install path, check this option.

When install the plug software RDPlug, under normal circumstances, the install program will locate to the target software automatically. If the installer does not locate to the target software automatically, you need to check this option, and locate to the target software manually.

6> Pen drawing lines

This option is only applicable to a particular machine, which has the function of the chalk line, ordinary machines do not need to check this.

7> Plug laserwork

The installer default install a special plug-ins RDPlug, if the users are more accustomed to using LaserWork program ,can check this.

8> Demo version installation

According to the type of software installation, the installation language, the choice of motherboard generate different versions of the DEMO Software.

II.2.3 Installation

Choose the type of software, installation language and the appropriate motherboard. Click **【Install】** to install the software. After installation is complete, the following dialog box appears to prompt the user that the software has been installed successfully.

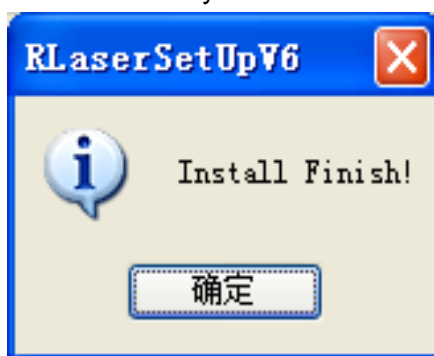

II.2.4 Exit

After installing the installation needed. Click **【Exit】** to end the installation process.

Because of the possible need to use several installation, so the installation dialog does not automatically exit, until users click button **【Exit】** .

II.2.4 Other matters

1> Before installing the plug-in software, the software that has been articulated should be shut down. After installation, restart the software.

2> The regular version and the DEMO version of the plug-in software is covered by each other.

3> In the default installation path, the normal version and the DEMO version of the independent software and different types of independent software motherboard with each other.

For the same time to install two versions, select the **【Locate install path】** .The regular version and the Demo version should be installed in the different location.

In addition, need to the appropriate software installation location, manually add a desktop shortcut for the software.

4> Modify the information of manufacturers

In the package, in addition to RDCAMSetup, there are four text files.

Info_Sche、 Info_Tche、 Info_En、 Info_Other, the four files correspond to the software information of manufacturers that be displayed in Simplified Chinese, Traditional Chinese, English and the custom language. If the four text is modified, manufacturer information also will be installed when the program was installed.

Open the text that should be modify, an example in Simplified Chinese:

0 = Company Name:

1 = ... (Fill in company name here)

And so on, the company information in other languages is the same set.